

BUILD YOUR OWN CLIMBING WALL

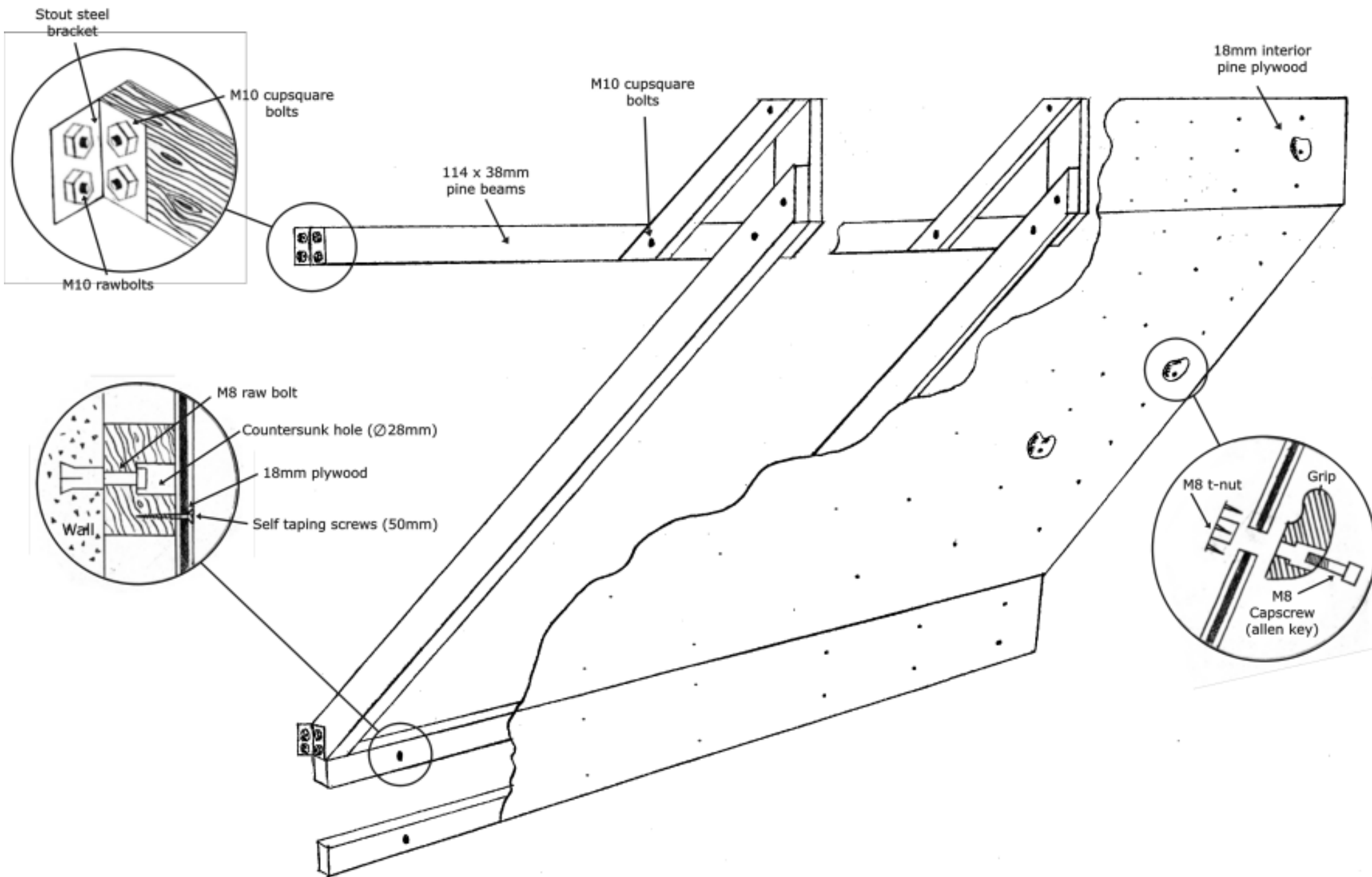

Depending on where you want to build your wall your design will probably differ but it will give you a good start. Try and use existing structural components in your garage or house such as stairs or beams.

An indoor wall is much better as you can train when the weather is bad and your wood will not get damaged by the elements. Essentially follow the following procedure:

- Invite all your mates around, get some nice cooldrinks and crank up some cool music.
- Drill a 200x200mm matrix of 10mm holes and then bang your M8 galvanised t-nuts in the back of your wooden panels (interior pine ply 18x1220x2440mm)
- Start with the bottom kickboard. Bolt 2 horizontal beams on the wall using countersunk holes and M10 rawl bolts. Then using self tapping 50mm screws screw the kickboard on. A 500mm high kickboard is advised.
- For a 2440mm wide wall, build 3 frames using 114x38mm rough pine beams. Bolt the beams together with M10x90mm cup square bolts or using beefy gangnails.
- Using stout steel brackets and M10 rawl bolts bolt the 3 frames on the wall so they will act as "ribs" to support the panels.
- Screw the panels on the frames using self tapping screws. Place the panels horizontally. A vertical section is recommended at the top of 500mm high and is also attached using self-taping screws. You may need to reinforce the corner between the panels with a block of wood screwed behind, between the frames.
- Buy some mattresses to soften your falls.
- Bolt on all those groovy GeckoGrips and get cranking!

Note> This is only a guide for building a climbing wall and GeckoGrips takes no responsibility for any incidents if your wall has not been built strong enough. Please consult a structural engineer if you are not sure.